



INSTALLATION, USERS AND SERVICING INSTRUCTIONS

SLIMLINE (FAN FLUE) HOTBOX **Inset Decorative coal or pebble effect Gas Fire**

For use with Natural Gas (G20) @ 20mbar inlet supply pressure only, as specified.
Country of destination: GB,IE,AT,CH,DK,ES,FI,IT,PT,SE for I2H = N.G. Only

Please read before using and retain for future reference.

***This product must only be installed by a CORGI registered person and
the installation must comply with these instructions***



FEF UK Ltd. Units 32 – 38 Intake Rd, Intake Industrial Estate, Bolsover,
Chesterfield, Derbyshire S44 6BB
Tel: 01246 823333 Fax: 01246 824444
Email: infor@fef.uk.com

-Please leave these instructions with the user-

Gas Council No. 32-045-07

Contents	Page
No:	
General	3-4
Technical Data	4
Instructions for use	
1. Operating the appliance	5
2. Cleaning	6
3. Fuel Bed arrangement	6/21/22
4. Flame Failure device and (ODS) Spillage monitoring System	7
5. Running In	7
6. Servicing	7
7. Ventilation	7
Instructions For Installation	
1.0 Site Requirements	
1.1 Location	8
1.2 Ventilation	9
1.3 Hearth	9/23
1.4 The Fireplace	10
1.5 Clearances From Combustible furniture	10
2.0 Gas supply and Connection	10
3.0 Electrical Supply and Connection	11
4.0 Installation	
4.1 Preparing the firebox recess	11
4.2 Installation onto non-combustible wall with fire in front of wall	11/12
4.3 installation into brick, block, stone cavity wall with fire recessed into wall	13
4.5 fitting the fire	14
4.6 Fitting the fan box assembly	15
5.0 Commissioning	15
6.0 Fuel Bed Arrangement	16/21/22
7.0 Checking For Spillage	16
8.0 Instructing the User	16
9.0 Annual Servicing	16/17
10.0 Replacement of Parts	18/19/20
Coal Bed lay instructions	21
Pebble bed lay instructions	22
Hole in the wall addendum	23

GENERAL

The '**Slimline**' Fan Flue Hotbox is an Inset Gas Fire intended for decorative purposes and designed to be used on natural gas only at a setting pressure of 20 mbar.

The appliance is only suitable for installation in G.B and I.E. and should be installed in accordance with the rules in force.

BS Codes of Practice

Relevant standard	Scope of standard
BS 6891	Gas Installation
BS 5440: Pt 1	Flues - Installation & Maintenance
BS 5440: Pt 2	Ventilation - Installation & maintenance
BS 5871: Pt 2	Installation of Inset Fuel Effect gas fires

In G.B this appliance must be installed and serviced by a competent person and in accordance with the relevant requirements of Gas Safety (Installation and Use) regulations 1998, the relevant British standards for installation, appropriate Codes of Practice, and in accordance with these instructions. It is recommended that a CORGI registered engineer be used for this purpose as they are approved by the HSE under the above regulations.

The installation shall also be completed in accordance with:

The Building Regulations issued by The Department of the Environment

The Building Standards (Scotland) Regulations issued by the Scottish Development Department

In The Republic of Ireland this appliance must be installed and serviced by a competent person and in accordance with the rules in force and **reference should be made to the relevant standards governing installations (IS 813: 1996)**

Read these instructions before installation and use.

This appliance does not normally require any purpose provided ventilation when installed in GB. **For IE refer to relevant standard (IS 813: 1996).**

Any purpose provided ventilation must be checked periodically to ensure that it is free from obstruction.

It is important for the correct operation of the appliances that the fuel bed components are assembled in accordance with these instructions. Only use original replacement components available from the manufacturer.

It is recommended that a fire guard conforming to BS 8423:2002 is fitted for the protection of young children, the elderly or infirm.

Under no circumstances shall rubbish be thrown onto the fire.

Any combustible shelves or surrounding furniture must only be installed in accordance with the parameters detailed in these instructions.

The appliance is fitted with an Oxygen Depletion System pilot assembly, which will automatically cause shutdown of the main burner and pilot flame if there is insufficient oxygen due to lack of ventilation or the appliance is not clearing the products of combustion. **UNDER NO CIRCUMSTANCES SHALL THIS DEVICE BE ADJUSTED, BYPASSED OR PUT OUT OF ACTION.** The device must be regularly serviced and strictly in accordance with these instructions.

Under extreme wind conditions the fire may automatically turn off for short periods of time (approximately 5 minutes) before automatically re-lighting itself and returning to normal operation. During the off period the pilot will remain lit.

TECHNICAL DATA	
Category of appliance	I2H
Gas type and pressure setting	G20 at 20 mbar
Maximum heat input (gross)	6.4 kW
Minimum heat input (gross)	4.0 kW
Gas connection	8mm OD rigid or semi-rigid tube with 8mm compression fitting at the appliance inlet.
Controls and safety system	Rotary gas tap with permanent ODS pilot burner incorporating Flame failure device and piezo spark ignition. Aeration slider control for flame picture adjustment.
Injector size and marking	Injector ID 215
Electricity Supply	230 Volts - 50 Hz
Maximum Wall Thickness	570 mm
Minimum Wall Thickness	100 mm

INSTRUCTIONS FOR USE

1. OPERATING THE APPLIANCE

Refer to Figure 2 and the appliance control markings:

Ensure the control knob is pointing to the off position (OFF).

Ensure the mains power supply is turned on.

Press the 'Fan On' switch to start the fan operation. The green neon will be illuminated when the air pressure switch has been proven by the correct operation of the fan, indicating that the main burner of the fire can be lit.

Fully depress the control knob and rotate slowly in an anti clockwise direction towards the ignition symbol (⚡).

A click will be heard as the control knob is turned through this position and the pilot should light. **Note ~ The pilot flame can be viewed through the small hole in the center of the appliance front plate. (Photograph B).** Keep the control knob depressed at the pilot position for 10 to 15 seconds before releasing.

If the pilot fails to light repeat the above procedure.

With the pilot alight, depress the control knob slightly and rotate anti clockwise to the 'high' position (MAX). The main burner will now light.

To obtain lower flames rotate the control knob fully anti clockwise to the 'low' position (MIN).

To turn the main burner off, rotate the control knob clockwise to the pilot position. The main burner will be extinguished but the pilot will remain alight.

Press the 'Fan Off' switch to stop the fan. The green neon will go out indicating that the main burner cannot be re-lit without activating the 'Fan On' switch again.

To extinguish the pilot burner, rotate the control knob clockwise back to the (OFF) position. After turning off the appliance, or if the appliance should go out for any reason, wait at least 3 minutes before trying to relight.

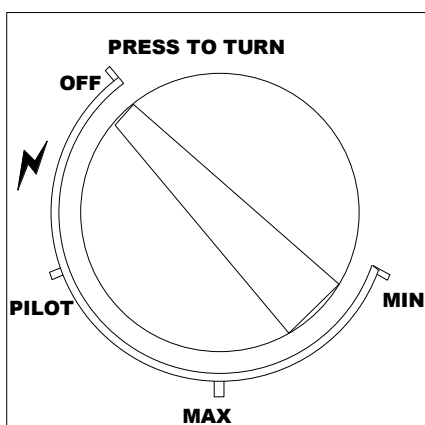

Fig 2. Control Knob



Photo B. Pilot viewing hole

2. CLEANING

**WARNING: DO NOT ATTEMPT TO CLEAN THE FIRE UNTIL IT IS IN A COLD CONDITION
THE FIRE WILL RETAIN ITS HEAT FOR A CONSIDERABLE TIME AFTER SHUTDOWN.**

Carefully remove the 9 loose coals or 7 loose pebbles and the ceramic fuel bed components and place to one side taking care to protect floor coverings etc. Care should be taken when removing the fuel bed components as they are very fragile. **DO NOT LIFT THE REAR CERAMIC BY THE TWO MOLDED COALS.**

Using a soft brush and vacuum cleaner remove any debris from the burner and ensure all ports are free from obstruction.

Clean around the pilot assembly with a soft brush and ensure that the aeration port is free from obstruction.

CAREFULLY clean the fuel bed components using a soft brush and/or a vacuum cleaner with soft brush attachment.

Replace the fuel bed components as detailed in section 3.

The brass fire trim may be cleaned using suitable soft cloth and cleaning solution.

3. FUEL BED ARRANGEMENT

The fuel bed consists of the following components:

1 off molded ceramic rear matrix

1 off molded ceramic front matrix

(2 off small random coals and 7 off large random coals) or (4 off medium pebbles and 3 off small pebbles)

If any fuel bed components are missing or damaged, replacements can be obtained from the manufacturer.

(Refer to the parts list detailed in section 10.0 at the rear of these instructions).

UNDER NO CIRCUMSTANCES SHALL THE APPLIANCE BE OPERATED WITH DAMAGED OR BROKEN CERAMIC COAL BEDS AND THE LOOSE COALS MUST BE LAID IN ACCORDANCE WITH THESE INSTRUCTIONS FOR CORRECT AND SAFE OPERATION OF THE APPLIANCE.

COAL LAY INSTRUCTIONS:-

Refer to the attached sheet at the rear of these instructions, headed 'Coal Lay Instructions'

PEBBLE LAY INSTRUCTIONS:-

Refer to the attached sheet at the rear of these instructions, headed 'Pebble Lay Instructions'

4. FLAME FAILURE DEVICE AND (ODS) SPILLAGE MONITORING SYSTEM.

The pilot assembly of the appliance incorporates a flame failure device which in the event of insufficient heat from the pilot flame on the thermocouple will automatically shutdown the gas supply to the appliance.

Additionally the pilot unit incorporates a system that will automatically shut the gas supply off to the appliance if the pilot flame goes out for any reason during operation of the fire due to insufficient supply of oxygen. The lack of oxygen can be caused by insufficient ventilation or the appliance not adequately clearing the products of combustion.

Continued operation of either device indicates that there may be a serious problem and a qualified gas engineer should be called to carry out an inspection.

DO NOT USE THE APPLIANCE UNTIL IT HAS BEEN CHECKED AND THE ENGINEER SAYS IT IS SAFE.

5. RUNNING IN

During the initial operation, the appliance may give off a harmless and temporary odour until the ceramic components have burnt off. This is normal, but should the odour persist seek further advice.

6. SERVICING

A qualified gas engineer (CORGI registered person) must service the appliance at least once a year.

7. VENTILATION

This appliance does not normally require any purpose provided ventilation when installed in GB. For IE refer to relevant standard (IS 813: 1996).

Any purpose provided ventilation for these appliances must be checked periodically to ensure it is free from obstruction.

INSTRUCTIONS FOR INSTALLATION

1.0 SITE REQUIREMENTS

1.1 LOCATION

The Slimline Fan Flue DFE fire must be installed on an outside wall with the terminal located in a suitable place.

The appliance is suitable for installation through a wall of thickness between 100 mm and 570 mm.

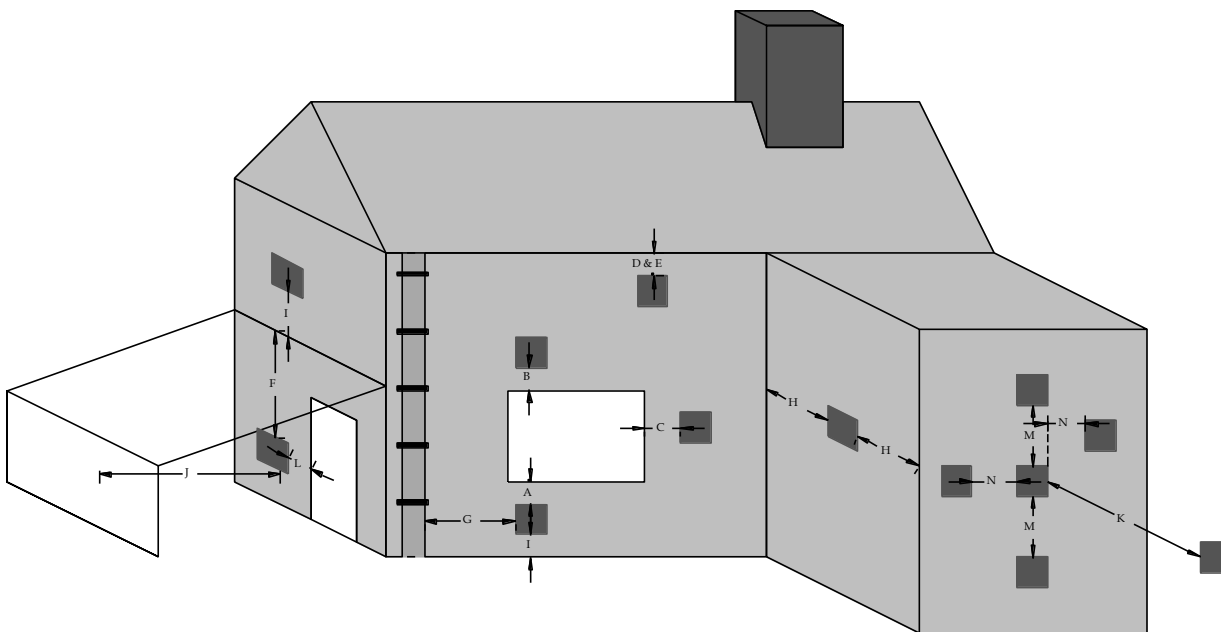

LABEL	TERMINAL POSITION	DISTANC E
A *)	Directly below an opening, air brick, opening window, door, etc.	300mm
B *)	Above an opening, air brick, opening window, door, etc.	300mm
C *)	Horizontally to an opening, air brick, opening window, door, etc.	300mm
D	Below gutters, soil pipes or drain pipes	75mm
E	Below eaves	200mm
F	Below balconies or car port roof	200mm
G	From a vertical drain pipe or soil pipe	150mm
H	From an internal or external corner	300mm
I	Above ground, roof or balcony level	300mm
J	From a surface facing a terminal **)	600mm
K	From a terminal facing a terminal	1200mm
L	From an opening in the car port into the dwelling	1200mm
M	Vertically from a terminal on the same wall	1500mm
N	Horizontally from a terminal on the same wall	300mm

1.2 VENTILATION

No purpose provided ventilation is normally required for these appliances, with normal adventitious ventilation being sufficient. Reference should be made to BS 5871 Part 2. For Ireland refer to IS 813 section 10 of the Irish ventilation requirements.

1.3 HEARTH

This appliance must be installed with a hearth as detailed, unless the 'hole in the wall' instructions are followed. See separate addendum at the rear of these instructions.

The hearth must consist of at least 12.5 mm thick non-combustible material. The periphery of the hearth must be at least 50 mm above floor level, or alternatively, a fender rail or upstanding edge of at least 50 mm height can be fitted to the periphery of the hearth. The hearth must extend at least 300 mm in front of the mounting wall face, and must be at least 600 mm wide, centrally displaced. These appliances must stand on a non-combustible base within the fire place opening which will be of equivalent height as the hearth.

Under no circumstances shall the appliance be fitted directly onto a combustible floor or carpet.

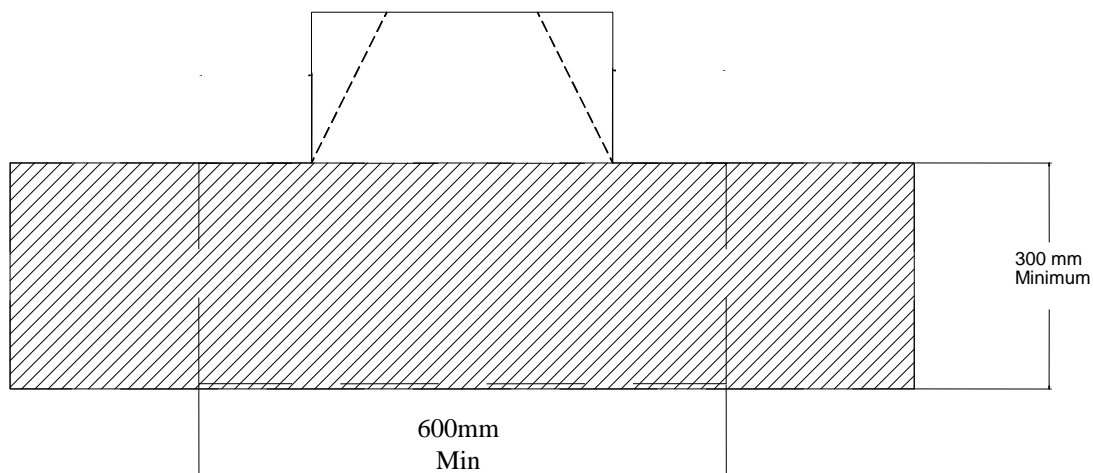

1.4 THE FIREPLACE

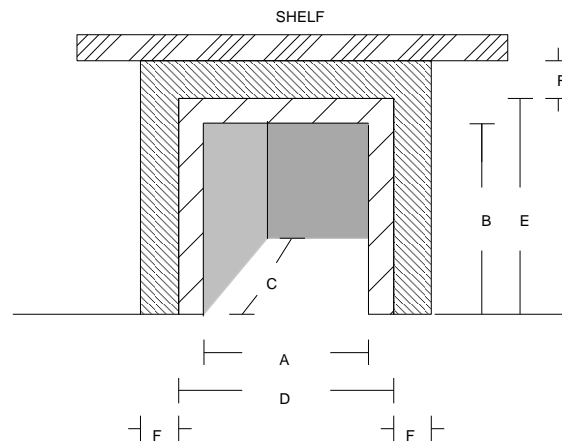

<u>Dimension Label</u>	<u>Distance required</u>
A (Opening Width)	360mm - 460mm
B (Opening Height)	540mm – 570mm
C (Opening Depth)	Minimum 130mm
D (Flat Surface Width)	Minimum 500mm
E (Flat Surface Height)	Minimum 605mm
F (Non combustible clearance)	Minimum 150mm

The fireplace opening must be within the dimensions detailed. There must be a flat area around the opening to allow for sealing back of the firebox. The appliances may only be mounted against a non combustible surface which must extend at least 150 mm past any edge of the appliance. If a combustible shelf up too 150mm deep (6”) is to be fitted above the appliance, a clearance of 150mm must be allowed. For every increase in shelf depth of 25mm, an additional 25mm clearance must be allowed.

2.0 GAS SUPPLY AND CONNECTION

The gas supply can be routed and connected through the opening at the right hand side and rear of the firebox. (Do not use the same hole for the electrical cables)
Rigid or semi-rigid tube shall be used with connection suitable for 8 mm compression.
Care should be taken to sleeve the supply pipe when routing through masonry.
An isolating valve must be fitted in the supply pipe to the appliance to facilitate servicing.

3.0 ELECTRICAL SUPPLY AND CONNECTION

All external wiring to the appliance must be in accordance with the latest I.E. wiring regulations, and any local regulations that apply.
Ensure cables are not pulled tight along their entire length and that it is possible to isolate the electrical supply to the fire for servicing.
In the event of an electrical fault after installation of the appliance, preliminary electrical system checks must be carried out, i.e.. Earth continuity, short circuit, polarity and resistance to earth.

THE APPLIANCE MUST BE EARTHED.

Any additional cable used should be 0.75mm² (24 x 0.2 mm) PVC heat resistant as specified in table 16 of BS 6500.

Where the cable passes through brickwork or masonry it should be suitably protected and sealed.

The appliance requires a suitable 230V~50Hz supply to the fan control box. The supply lead should be suitably routed to a double pole isolating switch with a contact separation of at least 3 mm in both poles or a suitable 3-pin socket with the plug fused at 3A. and which is readily accessible to the user to enable the electrical supply to be switched off as required.

4.0 INSTALLATION

Prepare the appliance for installation by fitting the flue duct to the rear of the appliance.

4.1 PREPARING THE FIRE BOX RECESS

GENERAL

Ensure that the chosen position will comply with the installation requirements detailed in section 1.

Attempt to keep the recess and hole sizes as close as possible to the minimum dimensions in order to keep the installation tidy without the need for excessive sealing afterwards.

Make sure the damp course and any electrical wiring or pipes in the wall are not going to be affected by the installation.

Any gas supply pipe concealed in the wall, floor or the cavity must be continuous and enclosed in a gas tight sleeve. (Gas safety (Installation and Use) Regulations 1998).

Ensure that a non combustible hearth is fitted in accordance with section 1.3, and that the fire is installed on non combustible wall face in accordance with section 1.4.

4.2 INSTALLATION INTO NON- COMBUSTIBLE WALL WITH FIRE IN FRONT OF WALL

This installation details the use of a fire surround or false chimney breast which must have a minimum depth of 100 mm. This allows the fire to be positioned in front of the wall with a hole in the inner wall for the flue only. The maximum depth of the false surround is dependent upon the thickness of the wall. The appliance can be installed against a wall up to a maximum thickness of 470 mm and a minimum thickness of 138 mm.

To protect any combustible materials used in the construction of the false chimney breast, suitable non combustible 24 mm thick 'superlux' or equivalent materials must be used to the top and to the sides of the appliance. These pieces should extend from the inside front face of the fire mounting surface to the inside face of the inner wall and should be at least as wide as the fire place opening. 50 mm of rock wool or equivalent material shall be used above the appliance to further protect any combustible materials.

Any combustible material to the rear of the appliance shall be removed (i.e.. wall coverings)

Mark off the height of the center of flue duct on the inside wall face and drill a pilot hole through to the outside.

Working from outside the building, make a hole in the outside wall to accept the fan box assembly taking consideration of hearth height. (See figure 8)

From inside the building, make a hole in the inside wall to accept the flue duct.

A separate hole should be made through the inside wall towards the bottom left hand corner of the fire location to enable the electric cables to pass through and connect the fan control unit within the fire box to the fan box assembly.

The wall cavity should be sealed where the fan box assembly and flue duct holes have been cut. Rock wool or equivalent may be used for this purpose and it should be fitted top, bottom and to the sides of any part of the assembly to a thickness of at least 50 mm.

Ensure that the false fire surround used is correctly and adequately sealed to the inner wall and that the appliance hotbox is sealed to the front face of the surround.

*Slimline powerflue.
Installations in front of a non-combustable wall.*

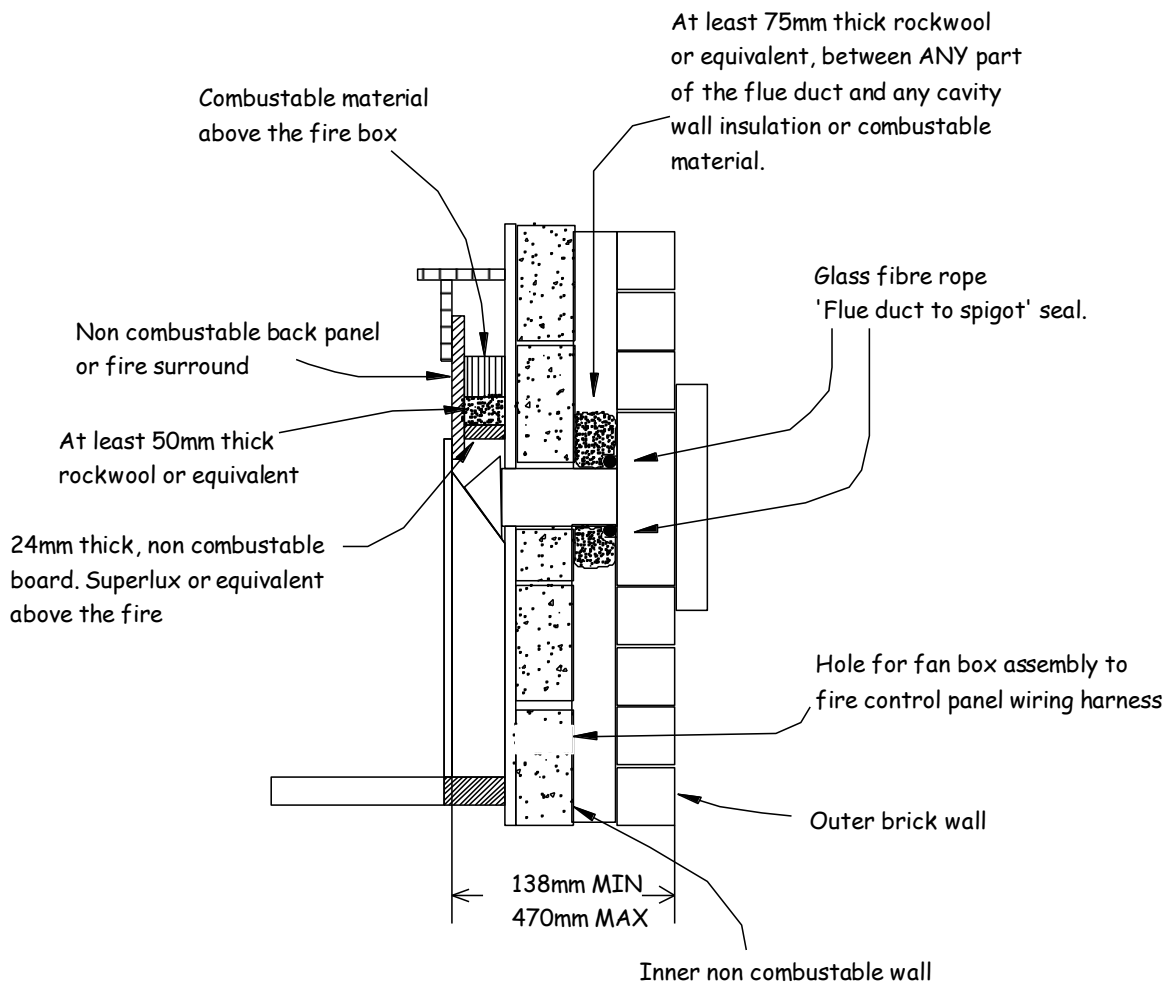

4.3 INSTALLATION INTO BRICK, BLOCK, STONE CAVITY WALL WITH THE FIRE FITTED INTO A RECESS

This installation details the site preparation for wall thickness between 238 mm and 570 mm.

Mark the position of the recess to be cut for the fire onto the inside wall.

A lintel may be required above the recess of the fire. If in doubt seek expert building advice.

Cut the recess in the inner wall for the fire ensuring that the depth of the fire box can be accommodated.

Measure and mark the position of the flue and drill a pilot hole through to the outside wall. Working from outside the building, make a hole in the outside wall to accept the fan box assembly. (See figure 8)

Ensure that any combustible cavity insulation material is removed to allow any part of the flue and fan box assembly to be surrounded with at least 50 mm of rock wool.

Slimline powerflue.

Installations into a non-combustable wall.

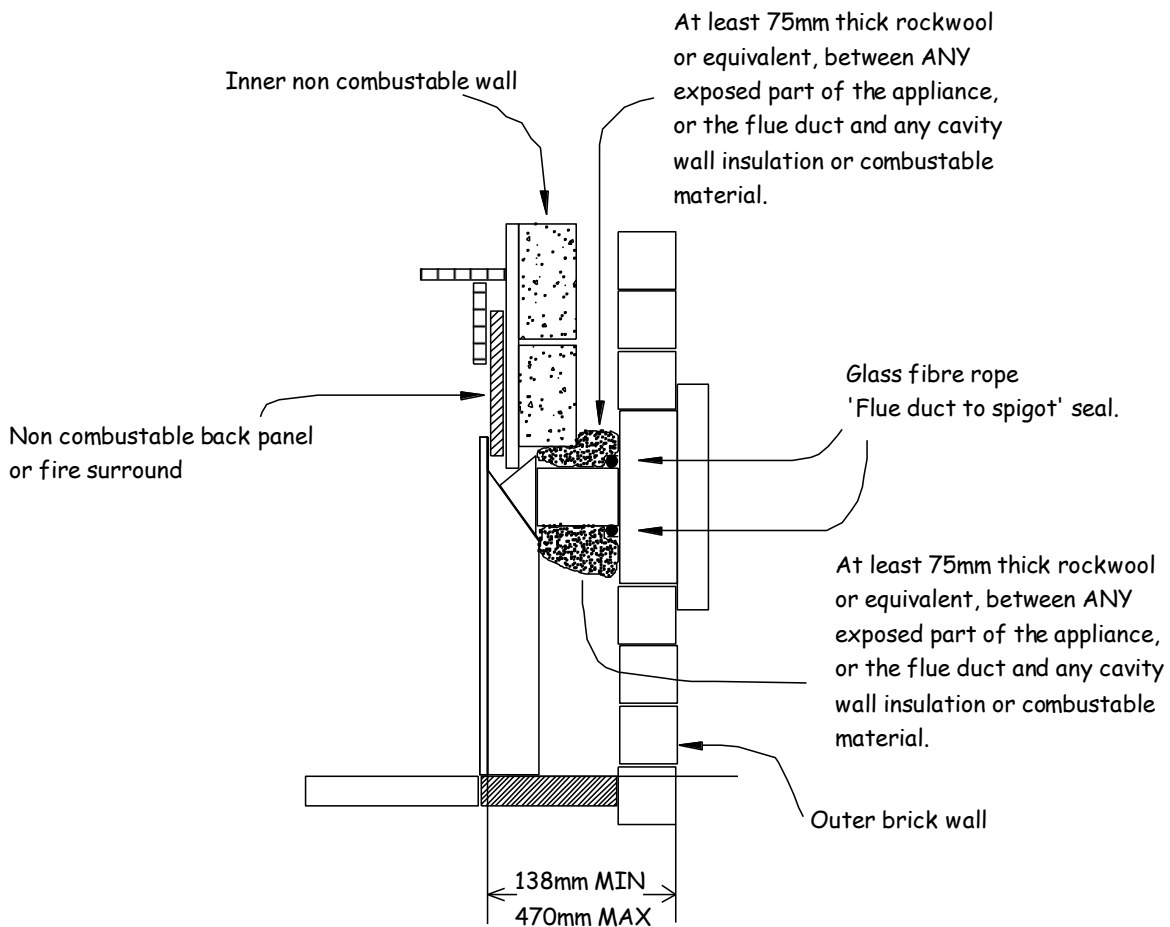

Fan Box installation Dimensions. Outer brick wall.

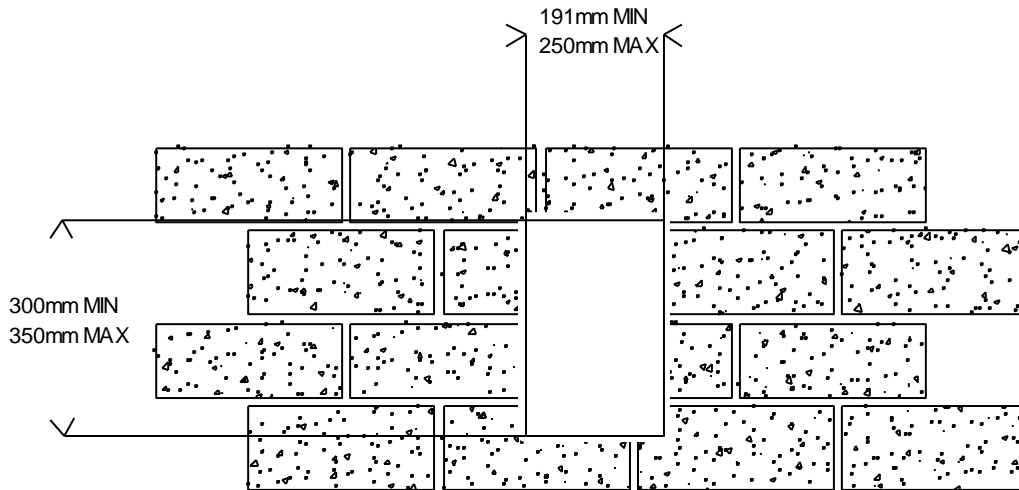

4.5 FITTING THE FIRE

Remove the curved fire front plate. This is done by carefully bending the plate outwards to release the locating tabs on either side.

Remove the burner chassis. To do this it is necessary to remove the securing nuts either side of the control valve bracket. The burner chassis will then pull forward and disengage from the firebox.

Using the fire fixing kit instructions fasten the fixing kit eyes into the back of the fireplace recess.

If fitting the appliance in front of the inner wall, the hotbox shall be positioned as required and the hole positions in the base plate marked for drilling and suitable wall plugs.

Position the firebox complete with flue duct into the opening, thus engaging the flue through the inner wall and to the outside. Ensure that the firebox is flat against the fire surround.

Working from outside the building, mark the flue duct flush with the outer face of the wall.

Remove the firebox from the fireplace opening. Measure 100 mm back from the mark made on the flue duct and cut using a hacksaw. It may be easier to remove the flue duct from the firebox before cutting.

Refit the flue duct.

Locate the fixing wire through the holes either side of the fire flue outlet on the back of the hot box. Thread the cables through the fixing eyes and back into the hotbox through the holes provided in the rear base area.

Stick the sealing tape to the inside edge of the hotbox outer frame.

Gradually position the firebox into the opening whilst feeding the silicone cable through the hole in the inner wall ready for connection to the fan box assembly.

Feed the gas supply pipe in through the firebox.

A 3 metre length of mains cable is supplied already attached to the unit which should be routed in readiness for connection to a suitable mains connection point. Should more than 3 metres of cable be required it will be necessary to disconnect the supplied cable within the fan control box and rewire a suitable length of identical cable.

Pull the firebox tight against the sealing tape and secure using the threaded screws onto the ends of the fixing cables. Further adjustments can be made using the fixing nuts.

If fitting the appliance in front of the inner wall, position the fire over the pre-drilled and wall plugged holes in the base plate and secure to the floor using suitable wall screws.

Refit the burner tray assembly ensuring the fan control unit to solenoid wiring harness is connected using the 4-way plug.

Connect the gas supply pipe to the appliance inlet elbow and carry out a gas soundness check up to the inlet connection.

Connect the mains supply cable to a suitable position - refer to Section 3.0.

4.6 FITTING THE FAN BOX ASSEMBLY

Remove the fan box assembly cover. Loosen the four screws securing the fan unit to the wall plate and separate placing the fan unit to one side. If necessary protect from the weather.

Offer up the assembly into the wall housing ensuring that the flue engages into the spigot on the rear of the wall plate and is central. Mark off the four wall fixing holes.

Drill and plug the four fixing holes and secure the wall plate in position whilst ensuring that the 5 core cable from the fire box is fed through the top right hand side of the wall plate.

Ensure the flue duct is sealed within the wall plate spigot using the glass fibre rope supplied.

Refit the fan unit ensuring correct entry of the cable.

Connect the 6 way plug into the free 6 way socket located to the top of the fan unit.

Refit the fan box assembly cover.

Seal all around the cover with a silicone based sealant to prevent the ingress of rain or moisture into the system.

A terminal guard is available as an optional extra if required and can be purchased from the appliance manufacturer quoting the part No. detailed in the parts list in section 10 at the rear of these instructions.

5.0 COMMISSIONING THE APPLIANCE

Turn on the gas service isolating valve and purge the gas line up to the inlet elbow of the appliance. Refit the inlet pipe at the inlet elbow and check for gas soundness at all joints using leak detection fluid.

Remove the pressure test point screw located on the outlet pipe of the gas valve and connect a suitable pressure gauge.

It is permissible for the appliance to be operated during the commissioning procedure for short periods without the need to assemble the coal bed.

Light the fire at the full on position in accordance with the operating instructions detailed in section 1. of the Users Instructions.

Check that the appliance setting pressure is 20 mbar (± 1.0 mbar).

The appliance is factory set and therefore **NO ADJUSTMENT IS REQUIRED**

Remove the pressure gauge and refit the screw.

6.0 FUEL BED ARRANGEMENT

To lay the fuel bed, refer to section 3 of the Users Instructions.

7.0 CHECKING FOR SPILLAGE

Before commencing with the checks for spillage, ensure all doors and windows are closed. Operate the appliance from cold for a period of 5 minutes at the full on setting. Note- It is advisable to allow the full 5 minutes in order to allow the fan to have established the normal run condition.

Fit a smoke match into a suitable holder, and position the lighted match 20 mm down from the underside of the fire canopy and 10 mm inside. This should be done no further than 50 mm from either side of the fire opening.

A visual check should ascertain that all smoke generated is being drawn back into the fire. If smoke enters the room, operate the appliance for a further 10 minutes and repeat the test.

If spillage still persists and smoke enters the room, turn off the appliance and isolate until the problem can be resolved.

ANY SPILLAGE INDICATES AN INSTALLATION FAULT.

If the spillage test is successful, the test should be repeated with any extractor fans operating and connecting doors open to create the worst likely operating conditions.

8.0 INSTRUCTING THE USER

These instructions shall be handed over to the user for safe keeping and future use during cleaning and servicing procedures.

The user shall be instructed on how to operate the appliance safely.

The user shall be instructed on the need to maintain the correct coal bed arrangement in accordance with these instructions and shown the relevant section covering cleaning of the appliance.

The user shall also be instructed on the need for regular annual servicing by a suitably qualified gas engineer (CORGI registered) to ensure continued safe operation of the appliance.

9.0 ANNUAL SERVICING

Servicing shall be carried out at least once a year by a suitably qualified gas engineer (CORGI registered) to ensure the safe and correct operation of the appliance.

Prior to commencing with any servicing or replacement of parts, the appliance must be turned off from the gas supply at the isolating valve. The electricity supply must also be isolated.

Ensure the appliance is cold.

FOLLOWING ANY DISMANTLING OF THE APPLIANCE DURING THE SERVICING PROCEDURE A GAS SOUNDNESS CHECK MUST BE CARRIED OUT.

CAUTION: *The ceramic components of the fuel bed are very fragile and extreme care must be taken when handling. Never use any other coals than those supplied by the appliance manufacturer, and never put additional coals on the fire.*

Ensure that any floor covering are suitably protected before commencing.

Carefully remove all the loose coals or pebbles and place to one side. The coals/pebbles can be carefully cleaned if there are any signs of soot formation using a soft brush.

Carefully remove the front ceramic matrix and using a soft brush, clean if necessary. Carefully remove the rear ceramic matrix DO NOT LIFT OUT WITH THE TWO MOLDED COALS and using a soft brush clean if necessary. Any damaged or broken ceramic components should be replaced.

Remove the appliance curved front plate by bending outwards to disengage the locating tabs.

To clean the burner and the pilot assembly it is not necessary to remove the burner chassis from the appliance fire box, thus it is not necessary to break any gas connections. Vacuum and / or brush the burner ensuring that none of the burner ports are obstructed. Ensure that the aeration port below the injector inlet is free from lint or debris. Clean the pilot assembly with a soft brush. Check that the small aeration port is not obstructed. Check for any signs of pilot assembly damage (i.e.. Ceramic cracking) and replace if necessary. The pilot assembly can only be exchanged as a complete unit. Check that the pilot ignition spark is operating by rotating the gas valve control device and if necessary adjust the spark gap to between 3.5 to 4.5 mm. This can be done by gently bending the ignition probe into position. Replace the front and rear ceramic matrices and the loose ceramics in accordance with Section 3 of the User Instructions

From the outside (at the fan box) remove the fan box cover (4 screws). Remove the four screws which secure the fan box assembly to the wall plate. Dismantle the fan from the fan box and clean the impeller blades of any soot or debris. With the fan removed inspect the flue duct and clear any soot or debris. Refit the fan and the fan box cover.

Ensure that the flue outlet terminal is not damaged and is free of obstructions.

With the gas and electricity supply on and the fan on check the ignition of the pilot. Check that the main burner cross lights satisfactorily from the pilot.

Carry out the commissioning instructions and check for satisfactory flue flow by carrying out a spillage test.

10.0 REPLACEMENT OF PARTS

WARNING: Isolate the gas and electricity supplies to the appliance before changing any components

Parts List

Part No.

Control knob
Control valve solenoid valve
Main burner injector
Pilot / ODS assembly
Ceramic rear and side cheek set
Ceramic matrix
Loose coal/pebble set
Inlet Elbow
Fan
Air Pressure Switch
Low limit Thermostat
High limit thermostat
Resistors
PCB
Flue duct
Fan box cover

10.1 To replace the pilot / oxygen depletion system.

- 10.1.1 Remove all loose ceramic components and place to one side.
- 10.1.2 Remove the curved front plate by disengaging the tabs from the side slots.
- 10.1.3 Undo the compression nut at the gas inlet elbow and disengage the pipe.
- 10.1.4 Undo the two burner assembly fixing nuts either side of the gas control valve bracket. Withdraw the burner assembly whilst disconnecting the fan control unit to solenoid harness at the plug.
- 10.1.5 Remove the HT lead from the pilot assembly.
- 10.1.6 Undo the pilot pipe nut at the pilot assembly and disengage.
- 10.1.7 Undo the thermocouple nut at the rear of the gas control tap and disengage.
- 10.1.8 Remove the pilot assembly from the burner tray.
- 10.1.9 Replace the pilot assembly and re-assemble the appliance in reverse order.

10.2 To replace the main burner

- 10.2.1 Remove all loose ceramic components and place to one side.
- 10.2.2 Remove the curved front plate by disengaging the tabs from the side slots.
- 10.2.3 Undo the compression nut at the gas inlet elbow and disengage the pipe.
- 10.2.4 Undo the two burner assembly fixing nuts either side of the gas control valve bracket. Withdraw the burner assembly whilst disconnecting the fan control unit to solenoid harness at the plug.
- 10.2.5 Undo the two pilot assembly fixing screws.
- 10.2.6 Undo the two compression nuts at either end of the injector manifold pipe.
- 10.2.7 Undo the two stud fixing nuts holding the burner to the assembly and remove the burner.
- 10.2.8 Unscrew the injector from the end of the burner and re-fit to the replacement burner.
- 10.2.9 Fit the new burner back into the assembly and re-assemble the appliance in reverse order.

10.3. To replace the injector

- 10.3.1 Remove all loose ceramic components and place to one side.
- 10.3.2 Remove the curved front plate by disengaging the tabs from the side slots.
- 10.3.3 Undo the compression nut at the gas inlet elbow and disengage the pipe.
- 10.3.4 Undo the two burner assembly fixing nuts either side of the gas control valve bracket. Withdraw the burner assembly whilst disconnecting the fan control unit to solenoid harness at the plug.
- 10.3.5 Undo the two pilot assembly fixing screws.
- 10.3.6 Undo the two compression nuts at either end of the injector manifold pipe.
- 10.3.7 Undo the two stud fixing nuts holding the burner to the assembly and remove the burner.
- 10.3.8 Unscrew the injector from the end of the burner and replace.
- 10.2.9 Fit the burner back into the assembly and re-assemble the appliance in reverse order.

10.4. To replace the ceramic back and side cheeks

- 10.4.1 Remove all loose ceramic components and place to one side.
- 10.4.2 Remove the curved front plate by disengaging the tabs from the side slots.
- 10.4.3 Prize the base of the rear ceramic back panel outwards and withdraw from the upper locating tabs.
- 10.4.4 Prize the rear of the side cheeks outwards and disengage from the front locations.
- 10.4.5 replace the three ceramic pieces in reverse order ensuring correct location behind tabs where applicable.
- 10.4.6 Re-assemble the appliance in reverse order.

10.5. To replace the gas control device

- 10.5.1 Remove all loose ceramic components and place to one side.
- 10.5.2 Remove the curved front plate by disengaging the tabs from the side slots.
- 10.5.3 Undo the compression nut at the gas inlet elbow and disengage the pipe.
- 10.5.4 Remove the control knob
- 10.5.5 Undo the two burner assembly fixing nuts either side of the gas control valve bracket. Withdraw the burner assembly whilst disconnecting the fan control unit to solenoid harness at the plug.
- 10.5.6 Remove the HT lead from the pilot assembly
- 10.5.7 With the burner assembly withdrawn from the appliance, invert and disconnect the gas inlet pipe, the gas outlet manifold and the pilot pipe compression nuts.
- 10.5.8 Remove the thermocouple connection on the back of the valve.
- 10.5.9 Undo the nut securing the valve spindle to the control valve bracket and withdraw the valve.
- 10.5.10 Replace the valve and re-assemble the appliance in reverse order.

- 10.3.1 Carry out procedures 10.2.1 to 10.2.5 inclusive.
- 10.3.2 Remove the 6 crimp tags from the relay.
- 10.3.3 Remove the two relay retaining nuts and withdraw the unit.
- 10.3.4 Replace unit and re-assemble in reverse order.
- 10.3.5 **Ensure the fan box cover is suitably sealed with silicone to prevent the ingress of weather.**

10.6 To replace Fan assembly resistor(s)

- 10.6.1 From outside, remove the four screws retaining the fan box cover and remove the cover.
- 10.6.2 Disconnect the two air pressure switch sensing tubes from the air pressure switch.
- 10.6.3 Disconnect the mains supply plug at the top right hand side of the fan box.
- 10.6.4 Undo the screws retaining the PCB / air pressure switch bracket and withdraw from the fan box.
- 10.6.5 Remove the three crimp tabs from the fan.
- 10.6.6 Undo the two resistor fixings and remove the wire connections.
- 10.6.7 Remove the resistor and replace. Re-assemble the appliance in reverse order ensuring that the fan box cover is suitably re-sealed to prevent the ingress of weather.

10.7 To replace the Low Limit Thermostat

- 10.7.1 Remove the fan box cover (4 screws)
- 10.7.2 Undo the two thermostat crimp tags and the two retaining screws.
- 10.7.3 Replace the thermostat and re-assemble the appliance in reverse order.
- 10.7.4 **Ensure the fan box cover is suitably sealed with silicone to prevent the ingress of weather.**

10.8 To replace the APS.

- 10.8.1 Carry out procedures 10.6.1 to 10.6.5 inclusive.
- 10.8.2 Undo the two APS fixing screws.
- 10.8.3 Remove the APS and replace. Re-assemble the appliance in reverse order.
- 10.8.4 **Ensure the fan box cover is suitable sealed with silicone to prevent the ingress of weather.**

10.9 To replace the fan

- 10.9.1 Carry out procedures 10.6.1 to 10.6.5 inclusive.
- 10.9.2 Undo the 4 screws retaining the fan unit and withdraw.
- 10.9.3 Undo the 3 fan fixing screws and remove the fan.
- 10.9.4 Replace the fan and re-assemble the appliance in reverse order.
- 10.9.5 **Ensure the fan box cover is suitable sealed with silicone to prevent the ingress of weather.**

10.10 To replace the High limit thermostat

- 10.10.1 Remove the fan box cover (4 screws)
- 10.10.2 Undo the two thermostat crimp tags and the two retaining screws.
- 10.10.3 Replace the thermostat and re-assemble the appliance in reverse order.
- 10.10.4 **Ensure the fan box cover is suitably sealed with silicone to prevent the ingress of weather.**

10.11 To replace the PCB

10.12 To replace the Fire solenoid valve

Slimline fire – Coal lay instruction

Carefully position the front moulded ceramic matrix onto the front of the burner tray. Ensure it is central and that the front lip sits over the edge of the fire front plate.



Place 2 small random coals into the back corners as illustrated.



Firstly, place 2 large random coals on the outer edges of the front matrix. These should be securely located within the grooves on the front coal matrix and lean backwards, resting against the rear matrix.

Place 2 large random coals evenly between these, once again securely located within the grooves of the front coal matrix and leaning back against the rear matrix.



Locate the next 2 large random coals, one to the left and the other to the right of the fire opening and bridge the gaps between the coals described above.

The final large random, rests between the 2 moulded coals on the rear matrix, and bridges the gap between the front row of coals and the rear matrix in a central position.

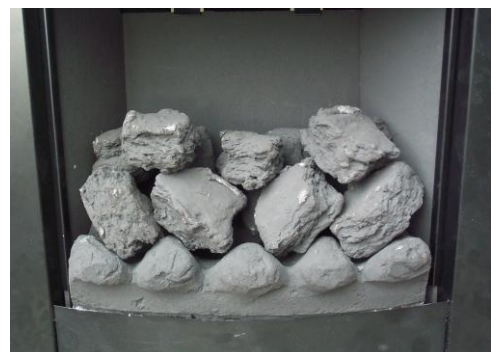

Slimline fire – Pebble lay instructions

Carefully place the rear moulded ceramic matrix onto the back of the burner tray, and push fully back and central in the fire opening.

DO NOT LIFT WITH THE MOULDED CERAMIC COALS



Carefully position the front moulded ceramic matrix onto the front of the burner tray. Ensure it is central and that the front lip sits over the edge of the fire front plate.



Place 2 small pebbles into the back corners as illustrated.



Firstly, place 2 large pebbles on the outer edges of the front matrix. These should be securely located within the grooves on the front coal matrix and lean backwards and outwards, resting against the rear matrix. The larger end should be onto the front ceramic matrix.

Place 2 large pebbles evenly between these, once again securely located within the grooves of the front coal matrix and leaning back against the rear matrix. Also with the large end against the front ceramic matrix.

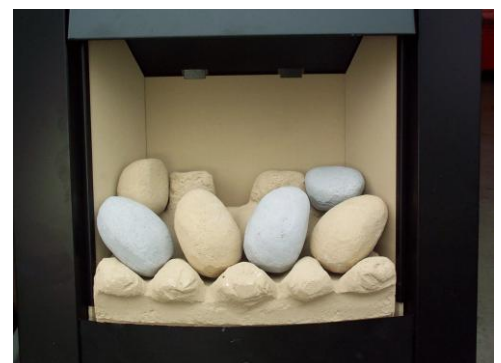

Position the final small pebble central in the fire bed, resting between the 2 moulded coals on the rear matrix, and bridging the gap between the rear matrix and the medium pebbles as described above.



Addendum for Hole in the Wall applications.
 Covers all models, must be used in conjunction with the issued installation instructions.

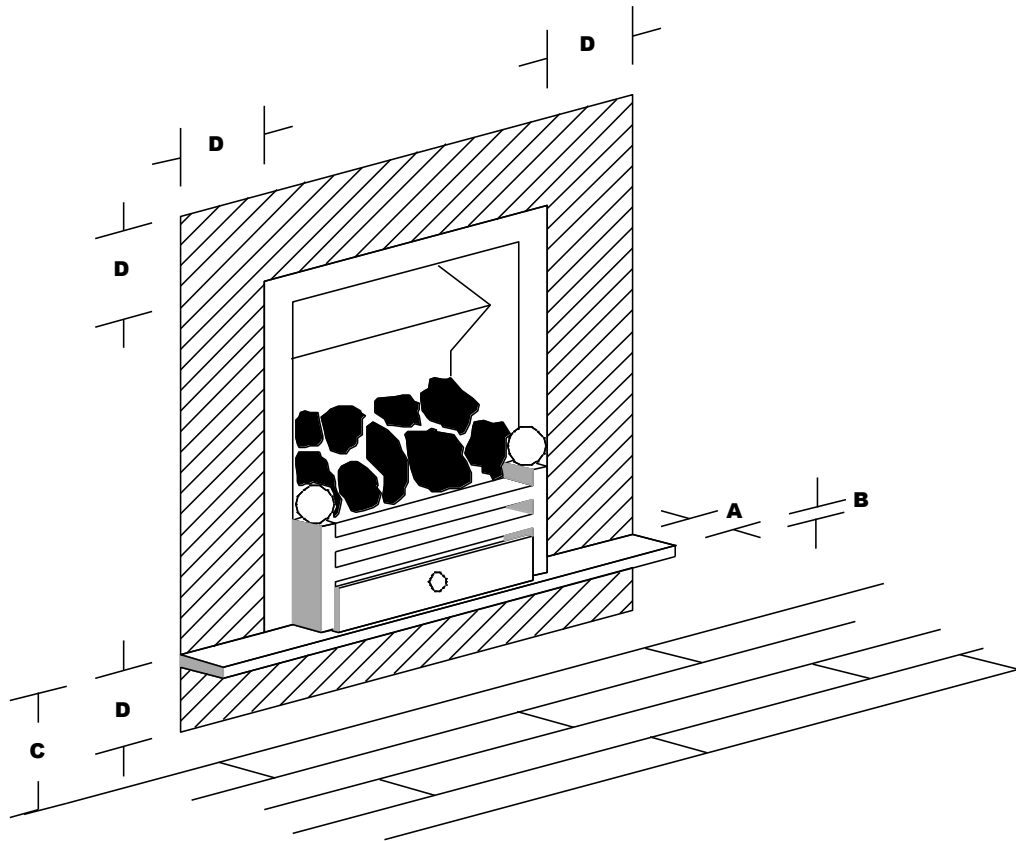

A	Plinth projection	Minimum 75mm
B	Plinth thickness	Minimum 20mm
C	Height of appliance base, from floor	Minimum 200mm
D	Non combustible clearance requirements	Minimum 150mm

This addendum must be used in conjunction with the issued installation instructions, and facilitates without the need for a projecting hearth, other than the plinth as detailed above.

All other installation requirements are as stated in the supplied Installation Instructions, and must be adhered to.